

**CROWN**

**Specifications**

**SC 4000 Series**

Sit-down  
Rider  
Lift Truck

SC 4000

Series



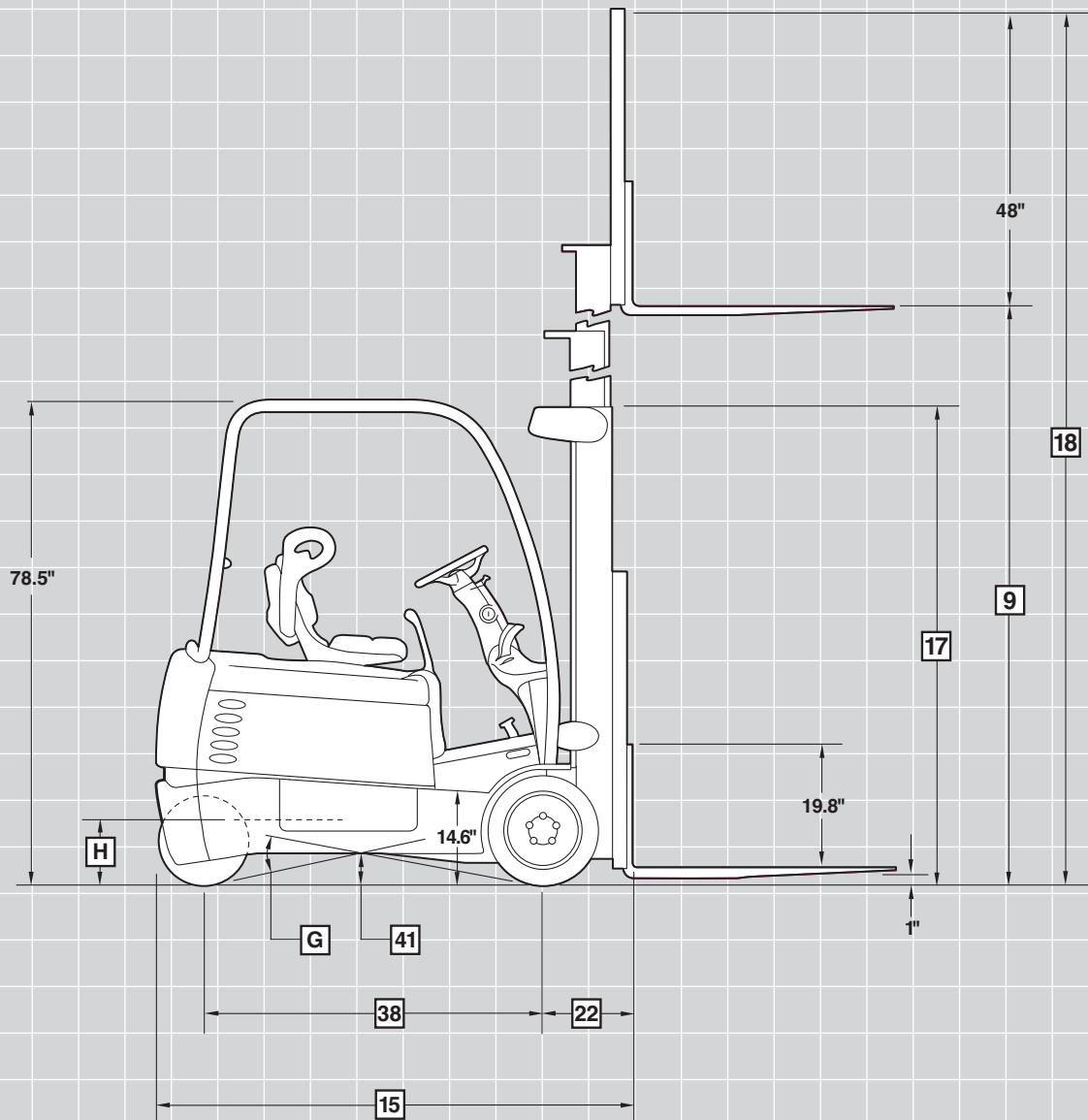
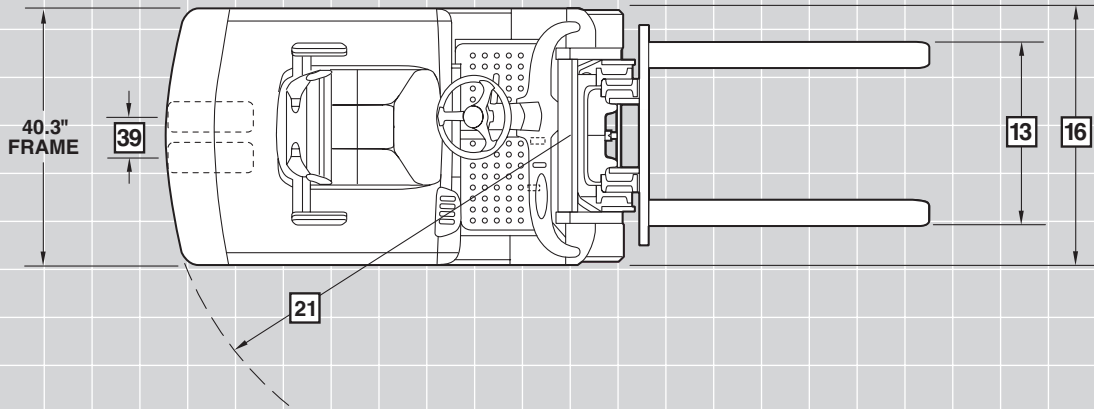

		Crown Equipment Corporation							
		4010-30	4020-30	4020-35	4040-35	4040-40			
General Information	1	Manufacturer	Crown Equipment Corporation						
	2	Model	SC	4010-30	4020-30	4020-35	4040-35	4040-40	
	3	Load Capacity*	Rated to 154 in	lb	3000	3000	3500	3500	4000
	4	Load Center	Fork Face to Load CG	in	24				
	5	Power	Electric	36 Volts					
	6	Operator Type		Sit-down Rider					
	7	Tire Type	Press-on Solid	Cushion					
	8	Wheels (x = driven)	Number Front/Rear	2x / 2					
Dimensions	9	Mast**	Lifting Height	in	190				
	11		Free Lift Height†	in	35				
	12	Fork Carriage		ITA Class II					
	13	Forks†††	Standard L x W x T	in	36 x 4 x 1.5	36 x 4 x 1.5	36 x 4 x 1.75	36 x 4 x 1.75	36 x 4 x 1.75
			Optional Lengths	in	30, 39, 42, 45, 48, 54, 60				
			Fork Spread–Min/Max		9/33	9/33	9/33	9/33	9.5/36
	14	Tilt	B°/F°	degree	5 / 5				
	15	Headlength		in	67.9***	72.4***	72.6***	77.2***	77.2***
	16	Width Overall†††	Standard Tread	in	40.3	40.3	40.3	40.3	42.3
	17	Height	Mast Collapsed	in	83				
			Mast Extended†	in	238				
	21	Turning Radius		in	53.6	58.1	58.1	62.7	62.7
	22	Load Distance	Center of wheel to fork face	in	14.3***		14.5***		
	23	Aisle Width	Right Angle Stack	in	Turn Radius + Load Distance + Load Length + Clearance				
	Speeds	24	Speed Travel††	Empty/Loaded	36V mph	8.0/7.5	8.5/7.7	8.5/7.7	8.5/7.7
25		Speed Lift††	Empty/Loaded	36V fpm	90/63	90/63	90/60	90/60	90/58
26		Speed Lower	Empty/Loaded	fpm	90/90	90/90	90/90	90/90	90/90
Weights	32	Weight, Less Battery		lb	6149	5974	6216	6040	6260
	33	Axle Load with Max Battery	Unloaded Front	lb	4047	4300	4316	4518	4506
			Unloaded Rear	lb	3852	3924	4150	4122	4355
Chassis	35	Tires	Number Front/Rear		2 / 2				
	36		Size Front	in	18x7x12.1	18x7x12.1	18x7x12.1	18x7x12.1	18x8x12.1
			Size Rear	in	15 x 5 x 11.25				
	38	Wheelbase		in	45.6	50.1	50.1	54.7	54.7
	39	Tread Width	Front	in	33.3	33.3	33.3	33.3	34.3
			Rear	in	6.7				
	40	Ground Clearance, Loaded	Lowest Point	in	3.0				
	41		Center of Wheelbase	in	4.8	5.0	5.0	5.0	5.0
	G	Grade Clearance, Loaded		%	27.1	24.6	24.6	22.4	22.4
	42	Brakes	Service		Foot - Mechanical				
Parking				Hand - Mechanical					
Battery	44	Battery	Type		Lead Acid				
			Capacity	AH	510	680	680	850	850
			KWH	17.8	23.7	23.7	29.6	29.6	
	46		Weight - Min	lb	1475	1850	1850	2250	2250
			Weight - Max	lb	1750	2250	2250	2600	2600
			Size - Max	Length	16.01	20.50	20.50	24.88	24.88
				Width	38.81				
				Height	22.80				
H	Battery Floor Height	With Rollers / w/o Rollers	in	10.4/9.8					
Motors	47	Motors	Traction Motor, dia	in	7.5				
	48		Lift Motor, dia	in	6.7				
	57	Operating Pressure	For Attachments	psi	Up to 3100 psi				

\* Optional masts, attachments, longer load dimensions and higher lifting heights may result in derating of the capacity. Contact dealer.

\*\* Other mast heights available. See chart for other standard mast heights.

\*\*\* Add 4.25 inches for quad masts.

† Includes load backrest.

†† Performance specifications are based on a truck equipped with a 190" triple telescopic mast.

††† Wide tread standard on 4000 lb model, trucks equipped with quad mast or TT mast collapsed height above 89".

Fork spread is 36" with wide tread.

Mast Chart SC 4000 Series			TT					QUAD
9	Lifting Height	in	172	190	208	226	241	240
11	Free Lift Height*	in	29	35	41	47	52	36
14	Tilt B/F	degree	5/5	5/5	5/5	3/5	3/5	5/5
17	Mast Collapsed Height	in	77	83	89	95	100	84
18	Mast Extended Height*	in	220.5	238.5	256.5	274.5	289.5	288.5

\*Includes load backrest.

SC 4000 Series

Technical Information

**Standard Equipment**

1. Crown drive system with GE transistor controller
2. 36 volt system
3. Driveability standard features
  - 15" step height
  - Large, uncluttered floor-board
  - Rubber floor mat
  - Rubber accelerator and brake pedal
  - Large, entry/exit "window"
  - Contoured battery cover for easy entry/exit
  - Full suspension seat with seat belt and side restraint
  - Compact steering wheel and steering column
  - Infinitely adjustable tilt steering
  - Operator forward design for enhanced visibility
  - Low cowl for fork and floor visibility
  - Urethane covered control handles with tactile feedback
  - Natural position for forward/reverse selector
  - Parking brake with tone alert
4. Performance profiling
5. 350 amp battery connector
6. Hour meter
7. Battery discharge indicator
8. LED diagnostics with 16 fault memory
9. Color-coded wiring
10. Lift out or side removal battery access
11. Dual 15" steer tires
12. Large 18" cushion drive tires
13. Crown manufactured drive and lift motors
14. Mechanical disc brake with "regen" assist

15. Proportional rack and pinion steering
16. Steering speed limit
17. Overhead guard
18. 48" high load backrest
19. No tool lift out floorboards for service access
20. High visibility mast with in-line hose routing
21. O-ring face seal hydraulic fittings
22. 5° Forward/Reverse tilt

**Optional Equipment**

1. Anti-cinch seat belt
2. Battery rollers
3. Lift interrupt
4. Freezer and corrosion conditioning
5. Sideshifter
6. Hydraulic valves for attachments
7. Quick disconnect connectors
8. Steering spinner knob
9. Storage tray with armrest
10. Keyless on/off switch
11. Fork lengths
12. Polished and tapered forks
13. Load backrest heights
14. Non-marking smooth or lug rubber tires
15. Drive-in rack overhead guard
16. 10° Bottlers tilt
17. Fan
18. Fire extinguisher
19. Mirrors
20. Working lights
21. Flashing lights
22. Brake, tail and back-up light
23. Audible travel alarms

**Driveability**

The SC 4000 benefits from Crown's design and engineering excellence. Numerous design features improve operator comfort and productivity.

A low 15" step height first greets the operator. A low battery cover that is streamlined helps the operator glide into the truck's seat. The overhead guard is shaped to open up the entry/exit window. The compact tilt steer column and steer wheel further facilitate entry/exit. Floorboards are large, uncluttered and rubber covered to insulate the operator from vibration. Brake and accelerator pedals are rubber covered to provide good grip and comfort.

Several designs contribute to better visibility everywhere you look. A low cowl for fork visibility, a unique waterfall overhead guard for load handling, a high visibility mast and a compact steer column all work for operator visibility.

Control handles are crafted into the compartment and "fanned" for easy selection. They are urethane covered with tactile feedback for comfort and easy selection. Control actuation forces are minimal and responsive.

**Crown Drive System**

Crown has applied the latest generation General Electric separately excited drive system. The demand for high efficiency systems that closely match customer torque requirements is met with this generation controller. By independently controlling the field and armature, the best attributes of both series wound and shunt wound motors is provided.

Transistorized dual motor controllers regulate both drive motors. Motors are designed and built in Crown's facility in New Knoxville, Ohio. Vertically mounted drive motors provide easy brush access. Floorboards remove without tools to expose motor ends.

Three modes of performance can be selected, (performance profiling), to accommodate operator experience or application requirements.

A distribution panel is conveniently located with all test points, control fuses and central wiring for easy troubleshooting. An optional handset plugs in to easily access service history and set performance features. An RS-232 serial link for extended and continuous status communications is standard. Utilizing the separately excited transistor control the forward, reverse and 1A bypass contactors needed in past designs is eliminated. This means fewer parts and electrical connections and fewer contactor tips which require maintenance.

### Proportional Rack and Pinion Steering System

Hydrostatic power steering uses a large, totally enclosed rack and pinion gear assembly.

The steering geometry is matched to the controller to deliver smooth steering at all angles. The advantage is less tire scrubbing which extends tire life.

Both motors receive power, even in the tightest turns. This helps the truck to accelerate, turn and maneuver even from a full turn start position.

A “steering speed limit” regulates the drive motor’s output by the turning degree of the truck. The advantage is smooth, stable steering which may increase operator confidence and productivity.

Large, (15" diameter) dual steer wheels provide good traction and stability.

### Mechanical Disc Brake with “regen” Assist

Both drive units have a brake assembly located on the intermediate shaft of the drive unit. This location creates a brake multiplication factor about 5:1. Braking is also assisted utilizing regenerative motor brake current. This solid state design reduces heat build-up and brake wear when braking and returns motor current to the battery. Brake rotor and friction pads are accessible through the mast assembly when brake inspection or replacement is performed.

### Hydraulics

The hydraulic system provides continuous filtration. A heat stabilized polymer hydraulic tank is free from contamination and retains strength over a wide range of temperatures. Hydraulic attachments can be added easily in the field using modular valve bodies. Hydraulic valve handle actuation is precise, and oil is controlled using metered spool valves.

Ram displacement type lift cylinders and two double acting tilt cylinders are Crown manufactured. All rams and piston rods are hard chrome plated to reduce pitting and extend cylinder packing life. O-ring face seal fittings are used to eliminate leaks.

### Mast Assembly

Crown manufactured mast assembly utilizes a “flush-face” interlocked I-beam design to improve visibility and save truck length. Roller bearing studs are welded on both sides of the rails for maximum strength and roller bearings are canted to run in the thick cross section of the rail. Tie bars wrap around the rails for added strength and to resist off-center load forces.

The hosing is applied using “in-line” routing to open up visibility. Cylinders are placed to the sides to create a high visibility design.

The mast has four points of attachment to the truck for good load force distribution. Two mounting points are at the frame, where tilt cylinders attach. Tilt cylinders use spherical bushings to resist off center load distortions. Two large diameter trunions secure the mast to the drive unit.

### Drive Units and Motors

Two independent double reduction gear drives offer 22.5 to 1 gear reduction. The first reduction uses spiral bevel gears for low noise and efficiency. The second reduction uses helical gears. The drive unit gears are constantly lubricated in an oil bath. The drive units position the drive motors upright for easy drive motor brush inspection.

This time proven design is quiet and reliable, providing years of trouble free service.

### Carriage

An ITA class II carriage is standard. An optional hook type ITA sideshifter or other attachments are easily added. Optional fork lengths are available.

### Other Options

1. Audible travel alarm
2. Flashing lights

Safety considerations and dangers associated with audible travel alarms and flashing lights include:

- Multiple alarms and/or lights can cause confusion.
- Workers ignore the alarms and/or lights after day-in and day-out exposure.
- Operator may transfer the responsibility for “looking out” to the pedestrians.
- Annoys operators and pedestrians.

### Other Options Available

Contact your Crown dealer.

*Dimensions and performance data given may vary due to manufacturing tolerances. Performance is based on an average size vehicle and is affected by weight, condition of truck, how it is equipped and the conditions of the operating area. Crown products and specifications are subject to change without notice.*



**Crown Equipment Corporation**  
New Bremen, Ohio 45869 USA  
**Tel** 419-629-2311  
**Fax** 419-629-3796  
[crown.com](http://crown.com)

Because Crown is continually improving its products,  
specifications are subject to change without notice.

Crown and the Momentum symbol are trademarks  
of Crown Equipment Corporation.

Copyright 1999-2004 Crown Equipment Corporation  
SF12735 Rev. 1/04  
Printed in U.S.A.